

the Piper Focus

Curved Grab-N-Go Adds Area and Appeal

Another attractive offering in Piper Merchandisers

Piper's continuous commitment to product improvement is easily seen in our complete line of Grab-and-Go Refrigerated Merchandisers. Recently (Vol. 18) we focused on the newly available rear-access feature. Now we turn our attention to the front of the unit. Piper designers have added another optional feature that is as attractive as it is practical. By curving the shelves outward, the display area was increased by 23% while the footprint only grew one square foot!

Features and options remain the same, including LED lighted shelves, powder coated interior panels, and laminated exterior panels. Choose from one of our 4 standard finishes, or customize it with any other color.

Discover this innovative design feature yourself. Order your curved Grab-N-Go Merchandiser now, then check out www.piperonline.net for more food-focused equipment.



Standard Colors

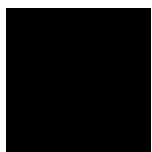

Black



Violin

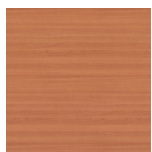

Pearwood

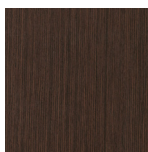

Kona Blend

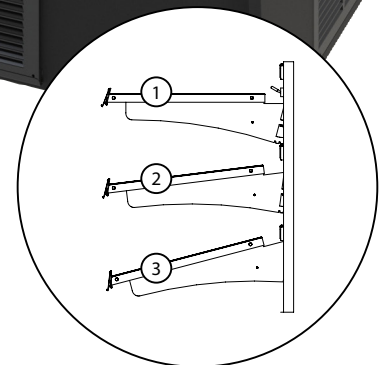

Shelves can be adjusted to (3) different angled positions

PIPER

The Food-Focused Equipment Company

300 S. 84th Avenue • Wausau, WI 54401
 Phone: 800-544-3057 • Fax: 715-842-3125
www.piperonline.net