

JOB \_\_\_\_\_ ITEM # \_\_\_\_\_ QTY # \_\_\_\_\_



R1-TS

The Reflections Tray Stand is a must to begin your lineup. Its versatile design can provide for all the required utensils. This Reflections unit is compatible and will interlock with other Reflection units. This Tray Stand unit holds virtually all sizes of food trays.

**STANDARD FEATURES**

- ◆ Seamless, molded FRP body with smooth exterior and rounded corners
- ◆ 14-gauge stainless steel top with fully welded square turndowns on all sides
- ◆ 4" diameter swivel plate casters with brakes
- ◆ Interlocking mechanism is provided to interlock with other Reflections units

**MODEL NUMBER**

- R1-TS
- R2-TS

**DIMENSIONS**

- ◆ R1-TS - 36"H x 30"D x 28"L (single stack)
- ◆ R2-TS - 36"H x 30"D x 38"L (double stack)
- ◆ 36" height on all standard units

**STANDARD COLORS**

- Wine Red (RAL 3005)
- Signal Red (RAL 3001)
- Yellow (RAL 1021)
- Light Blue (RAL 5012)
- Gentiane Blue (RAL 5010)
- Water Blue (RAL 5021)
- Moss Green (RAL 6005)
- Squirrel Gray (RAL 7000)
- Black
- White
- ◆ Custom colors available
- ◆ Optional Graphics Packages available

**COMMON OPTIONS**

- ◆ Bullet feet
- ◆ Silverware dispenser
- ◆ See reverse side for additional options

**WARRANTY**

- ◆ One year parts and labor. Warranty is detailed on inside front cover of the price list.

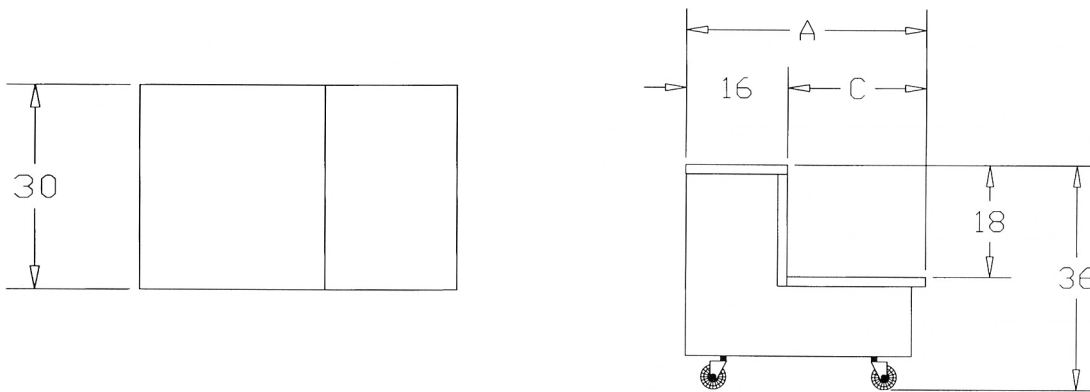

Model#	"A"	Width	"C"	Height	Ship Wt. (lbs)
R1-TS	30"	30"	14"	36"	155
R2-TS	38"	30"	22"	36"	195

R1-TS is single stack, R2-TS is double stack  
 Petite models are 30" high. Contact factory for details.

**OPTIONS / ACCESSORIES**

Part #	Description
<input type="checkbox"/> RBL	Stainless steel 6" adjustable bullet feet
<input type="checkbox"/> RSD	Silverware dispenser
<input type="checkbox"/> RSDN	Silverware and napkin dispenser

Note: Line-up drawing required when ordering interconnected units.

**B-12 SPEC**

**PIPER PRODUCTS**  
 BUILT TO LAST  
[www.piperonline.net](http://www.piperonline.net)

300 S. 84th Avenue  
 Wausau, WI 54401  
 Phone: 800-544-3057  
 Fax: 715-842-3125

**LIMITED WARRANTY:** PIPER PRODUCTS warrants to the original purchaser parts and labor for a period of twelve (12) months from the date of purchase. See manufacturer's complete warranty for details.

It is our policy to build equipment which is design certified by companies that have been accredited at the Federal Level by the Occupational Safety and Health Agency (OSHA) and ANSI as a National Recognized Testing Laboratory. These companies include CSA International, Underwriters Laboratories, and the National Sanitation Foundation. However, a continuing program of product improvement makes it necessary to submit new models to the agencies as they are developed. Consequently, all models may not bear the appropriate labels at all times.

We reserve the right to change specifications and product design without notice. Such revisions do not entitle buyer to corresponding changes, improvements, additions or replacements for previously purchased equipment. Information is not for design purposes.