

JOB _____ ITEM # _____ QTY # _____



ITD-4675

This product is made to transport inmate meals in insulated trays, plus accompanying beverages, in configurations large enough to serve up to 136 inmates per cart. These carts are designed and built to withstand the rigors of correctional handling while insuring the optimum in temperature maintenance.

STANDARD FEATURES

- ◆ Transports 2.5" x 13" x 15" thermal insulated trays
- ◆ All stainless steel construction
- ◆ Towable
- ◆ Inmate tough
- ◆ Designed to pass through 30" door or sally port
- ◆ Load capacity: 2000 lbs. (1000 lbs. per shelf)

OPTIONS

Part #	Description
<input type="checkbox"/> 8 x 2	Heavy-duty Casters (set of 4)
<input type="checkbox"/> WB	Wheel Brakes (set of 2)
<input type="checkbox"/> V	Vertical perimeter bumper

Straps are available in 96", 120", and 126" lengths. Please request pricing.

MODEL NUMBER

- ITD-4675
- ITD-4736

CONSTRUCTION

Frame to be 1.5" square stainless steel tubing. The bottom shelf frame will have four 1.5" square tube members and one 1.5" angle to provide tow strength integrity. The top and bottom shelf to be constructed of 14 gauge #304 stainless steel and to be welded to all frame members.

Cart to have 1" diameter stainless steel handle welded directly to frame. Cart to have four 6" diameter polyurethane casters, two rigid and two swivel.

CAPACITY

- ◆ 72-136 trays (feeds 2 or 3 pods per cart)

WARRANTY

- ◆ One year parts and labor. Warranty is detailed on inside front cover of the price list.

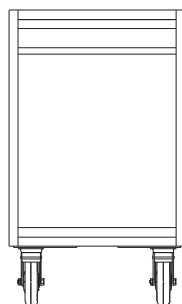
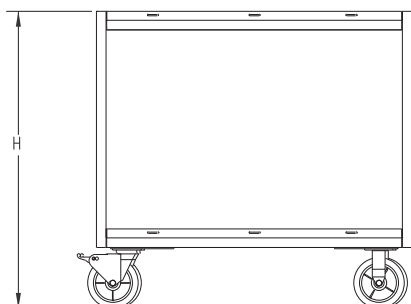
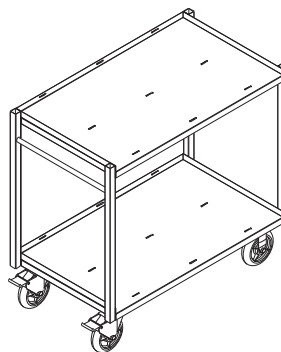
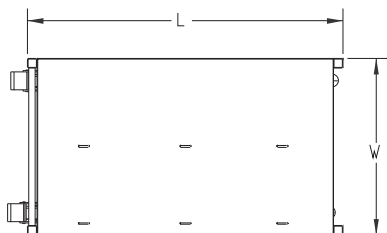

Model#	(A) Length	(B) Width	Height	Capacity	Ship Wt. (lbs)
ITD-4675	49"	28"	47"	72-104	300
ITD-4736	64-1/2"	28"	47"	96-136	390

OPTIONS / ACCESSORIES

- 8" pneumatic casters (recommended for towing)
- Towing package (1 hook, 1 receiver)

CAPACITY

ITD-4675

- ◆ 72-104 trays
- ◆ Lower Shelf: 72 Correctional Trays (plus 6 covers)
- ◆ Upper Shelf: 24-32 trays, plus 2-5 gallon beverage containers

ITD-4736

- ◆ 96-136 trays
- ◆ Lower Shelf: 96 Correctional Trays (plus 6 covers)
- ◆ Upper Shelf: 28-40 trays, plus 3-5 gallon beverage containers

F-10 SPEC

PIPER PRODUCTS
BUILT TO LAST
www.piperonline.net

300 S. 84th Avenue
Wausau, WI 54401
Phone: 800-544-3057
Fax: 715-842-3125

LIMITED WARRANTY: PIPER PRODUCTS warrants to the original purchaser parts and labor for a period of twelve (12) months from the date of purchase. See manufacturer's complete warranty for details.

It is our policy to build equipment which is design certified by companies that have been accredited at the Federal Level by the Occupational Safety and Health Agency (OSHA) and ANSI as a National Recognized Testing Laboratory. These companies include CSA International, Underwriters Laboratories, and the National Sanitation Foundation. However, a continuing program of product improvement makes it necessary to submit new models to the agencies as they are developed. Consequently, all models may not bear the appropriate labels at all times.

We reserve the right to change specifications and product design without notice. Such revisions do not entitle buyer to corresponding changes, improvements, additions or replacements for previously purchased equipment. Information is not for design purposes.