

JOB _____ ITEM # _____ QTY # _____

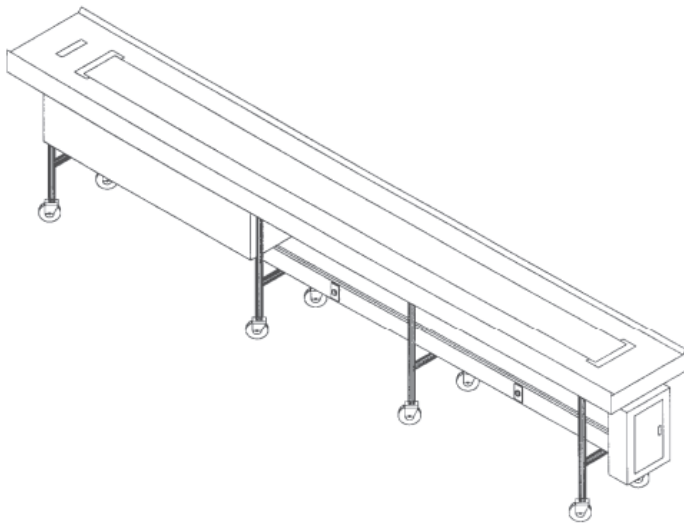

MODEL NUMBER

- Fabric- 8 Fabric-14 Fabric- 20
- Fabric-10 Fabric- 16
- Fabric- 12 Fabric-18

Fabric belt motorized conveyor is designed for tray make-up operations. All units can be equipped with electric raceway and breaker panel for online support equipment.

STANDARD FEATURES

- ◆ Variable speed
- ◆ "Air Glide" ride
- ◆ Pan limit switch
- ◆ Stationary
- ◆ Dry operation
- ◆ All welded heavy-duty frame

CONSTRUCTION

Drive housing is 18-gauge stainless steel and fully welded stainless steel angle and channel framework. Drive is totally enclosed fan cooled DC permanent magnet motor connected to a worm gear speed reducer, sprockets and roller chain. Fully lagged power roller with snubbed drive assembly providing 270-degree belt contact for positive drive. Rollers are crowned to assure proper tracking. Motor is controlled with SCR power transmission group; SCR main control panel has speed control station with stop-start controls.

SCR systems include dynamic breaking. All controls are NEMA 4 watertight. Shafting is solid stainless steel. Bearings are self-aligning ball bearings sealed for life.

Belt is two ply construction with PVC facing for easy cleanability and synthetic woven carcass on underside for friction free travel. Belt joint is machine set with stainless steel lacing and nylon lock rods.

Belt speed is electronically adjustable in speeds of 0-40 feet per minute. Conveyor slider pan is formed of stainless steel die embossed discs to provide "air glide" ride to prevent friction drag between belt and pan. Belt terminates at drive end to provide flat top space for one tray. Conveyor will stop as a tray reached checkpoint and will automatically restart when tray is removed.

WARRANTY

One year parts and labor. Warranty is detailed on inside front cover of the price list.

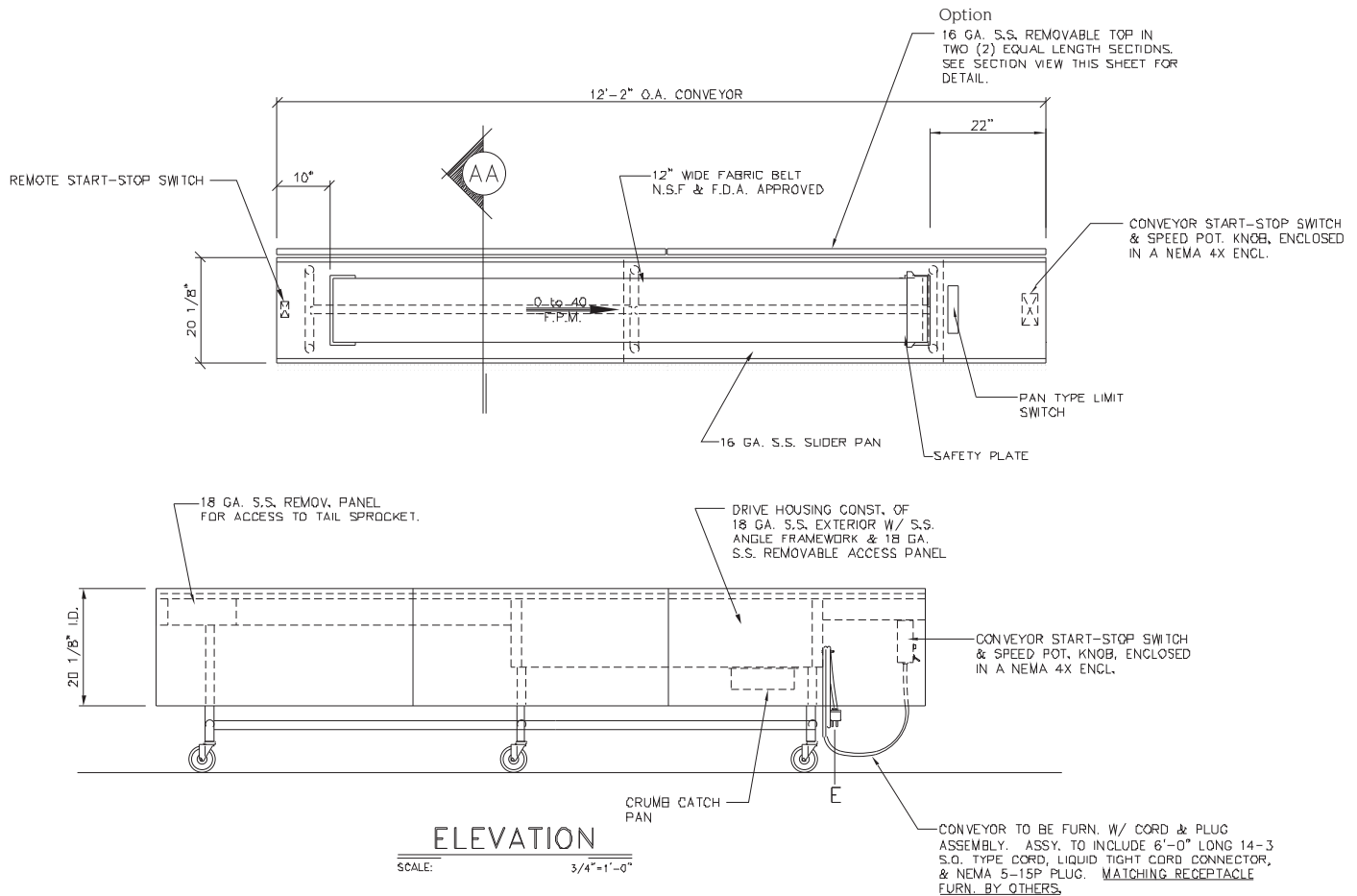

OPTIONS / ACCESSORIES

- Electric raceway
- Receptacles
- Casters
- Field joint
- Remote foot switch
- Wash system
- Cord & Plug
- Prison package
- 16 ga. Stainless Steel removable top

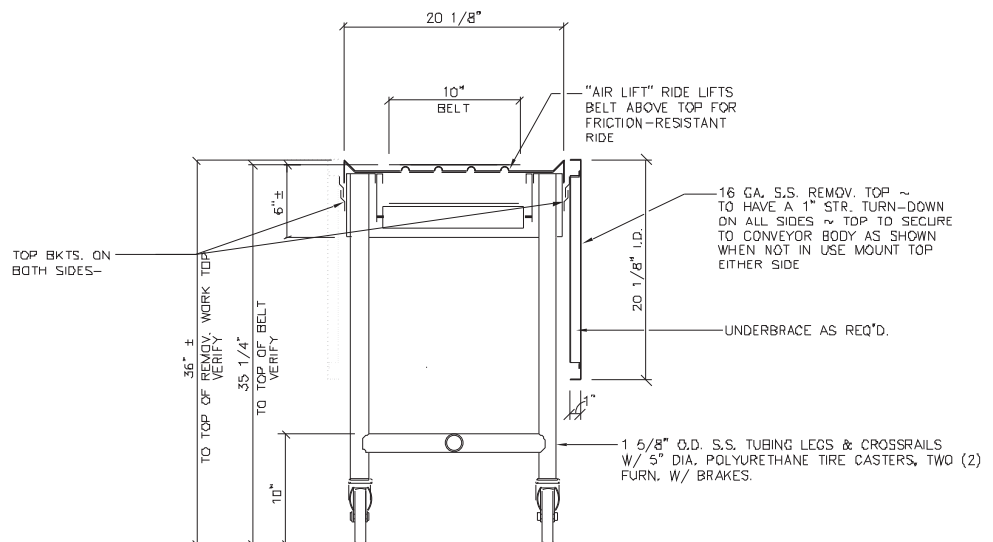

LIMITED WARRANTY: PIPER PRODUCTS warrants to the original purchaser parts and labor for a period of twelve (12) months from the date of purchase. See manufacturer's complete warranty for details.

It is our policy to build equipment which is design certified by companies that have been accredited at the Federal Level by the Occupational Safety and Health Agency (OSHA) and ANSI as a National Recognized Testing Laboratory. These companies include CSA International, Underwriters Laboratories, and the National Sanitation Foundation. However, a continuing program of product improvement makes it necessary to submit new models to the agencies as they are developed. Consequently, all models may not bear the appropriate labels at all times.

We reserve the right to change specifications and product design without notice. Such revisions do not entitle buyer to corresponding changes, improvements, additions or replacements for previously purchased equipment. Information is not for design purposes.

G-2 SPEC

PIPER PRODUCTS
BUILT TO LAST
www.piperonline.net

300 S. 84th Avenue
Wausau, WI 54401
Phone: 800-544-3057
Fax: 715-842-3125